

PSS 6-1A4 A

Model 876PH Intelligent Transmitter for pH, ORP, and ISE Measurement with HART[®] Communication Protocol



The Foxboro[®] brand Model 876PH is a 2-wire loop powered intelligent transmitter that, when used with appropriate electrochemical sensors, provides measurement, local display, and transmission of pH, ORP (Oxidation-Reduction Potential), or ISE (Ion Selective Electrode) concentration. The transmitter outputs a HART digital signal and a 4 to 20 mA analog output. Versions are available for use with both analog and Smart (digital) sensors.

FEATURES

- ▶ Either single sensor input (pH, ORP, or ISE), or dual sensor input sensor (simultaneous pH and ORP).
- ▶ 4 to 20 mA output with a HART⁽¹⁾ digital signal.
- ▶ Remote configuration/calibration with the HART hand-held communicator or PC-based configurator.
- ▶ Local configuration with the keypad on the integral local human interface.
- ▶ LCD indicator can display either one, two, or three measurement variables.
- ▶ Versions are available for use with both analog and Smart (digital) sensors.
- ▶ Input and Output Communications model code selection S (876PH-S) supports the PH10-*S Smart (digital) pH sensor and a real-time clock (RTC) function with power reserve.
- ▶ Fault isolation to transmitter or sensor.
- ▶ Galvanically isolated output.
- ▶ High impedance inputs for glass and reference electrodes.
- ▶ Approved/Certified as intrinsically safe device for use in hazardous area locations.
- ▶ Field Device Tool (FTD) certified DTM (Device Type Manager).
- ▶ Continuous transmitter/sensor diagnostics.
- ▶ Temperature compensation/calibration curves.
- ▶ Two levels of passcode protection provided; configurable.
- ▶ Analog sensor input version is compatible with all Foxboro pH, ORP, and ISE sensors, and many non-Foxboro sensors. Smart transmitter is compatible with PH10-*S sensor.
- ▶ Complies with applicable NAMUR standards, and European EMC Directive 2004/108/EC.
- ▶ Enclosure meets IP66 and NEMA 4X ratings.

1. Usable with HART Versions 5, 6, and 7.

INTRINSICALLY SAFE DESIGN

The 876PH Transmitter complies with FM, CSA, ATEX, IECEx, and NEPSI standards for intrinsically safe and nonincendive apparatus in hazardous area locations. Refer to “Electrical Safety Specifications” on page 18.

MEASUREMENT INTEGRATION

This transmitter provides efficient integration of measurements into HART process control schemes. It operates by using a bidirectional digital signal superimposed on the 4 to 20 mA current signal. Remote communication of digital values plus status and configuration information can be achieved via HART communication protocol.

Configurators used with this HART version are:

- ▶ The HART Communicator (users having a HART Communicator for other devices can have them upgraded with Foxboro DDs to accommodate this transmitter).
- ▶ The local Human Interface (see previous section).
- ▶ A PC-based configurator.
- ▶ A Distributed Control System (DCS).

With HART, digital multidropping is permitted. This is the connection of several transmitters to a single communications line. Multiple transmitters can be connected on a single twisted pair of wires. See Figure 7.

SENSOR AND TRANSMITTER DIAGNOSTICS

These functions include View Faults, Check Sensor, Resume Faults, and View History; and include:

- ▶ Measurement, Compensation, and Analog Output Overrange and Underrange
- ▶ Coated Reference Electrode
- ▶ Aging Glass and Broken Glass Electrode
- ▶ Calibration Required
- ▶ Liquid Leakage into Sensor Body
- ▶ Failed Preamplifier
- ▶ Automatic Temperature Compensation (ATC) Short and ATC Open
- ▶ Sensor Response Time (876PH-S only).

You can enable or disable any of the listed faults.

Fault status is displayed in the main Diagnostic Menu. If there are no faults, then “No Active Faults” will be displayed. The user can suspend faults from the measurement status for one hour, and can resume faults at any time.

SAVE AND RESTORE CONFIGURATIONS

Configuring an electrochemical transmitter involves the setting of many parameters specific for the application. For example, measurement, electrode, temperature compensator, output, resolution, and damping are just a few of the parameters that can be configured. In some cases, a user may wish to employ the transmitter for more than one application (at different times). Rather than having to change several parameters, the 876PH allows the user to save up to two unique and complete configuration profiles, including in the case of the 876PH-T, the calibrations associated with those profiles. Either of these two profiles can be restored at any time to facilitate a quick and easy change of the transmitter to a pre-saved configuration. The 876PH-S does not include calibrations because the Smart sensor stores the most recent calibration in the sensor electronics. In addition to the two user profiles, the transmitter also includes a “factory default” configuration which allows the user to return the transmitter to its original factory configuration at any time.

DURABLE FIELD-MOUNTED ENCLOSURE

The 876PH is housed in a durable aluminum alloy enclosure, and designed to withstand severe field conditions. The enclosure has the dust tight and weatherproof rating of IP66 as defined by IEC 60529, and provides the environmental and corrosion resistant protection rating of NEMA 4X.

Its efficient DIN panel-size design allows easy mounting for panel, pipe, or surface applications. A hinged front door provides easy front access to field connections. Large spade lug terminals for analog sensor and communications connections facilitate quick maintenance and calibration procedures. The keypad overlay is constructed of polycarbonate material.

The transmitter can also be provided with an optional clear plastic storm door to prevent accidental activation of the front panel controls.

APPLICATION FLEXIBILITY

Microprocessor technology, coupled with a simple user interface, allows rapid customization of the transmitter to specific application requirements. In the case of the 876PH-T, ORP or ISE applications can be handled by simply reconfiguring the basic pH transmitter to the desired measurement. Temperature compensation is equally as flexible, as the transmitter offers the standard Nernst compensation for glass pH electrodes, as well as optional solution compensation for ammonia and user-defined transforms.

SECURE DATA AND CALIBRATIONS

Two levels of security (configurable) protect against unauthorized configuration/calibration changes, loss of data, and/or invalid measurement signals.

The first level typically permits access to routine maintenance functions, including calibration and output hold, as permitted by the second level of security.

The second level permits changes to configuration parameters by authorized personnel.

Measurement loop security is enhanced by a user programmable “fail signal” parameter activated by any transmitter fault and certain serious sensor faults. This “fail signal” parameter forces the transmitter output to off-scale Fail High or Fail Low per NAMUR Standard NE 43.

INTELLIGENT CALIBRATIONS

Calibration routines are designed for simplicity and elimination of errors. All procedures are self-prompting. Two calibration routines are available. A “manual” calibration is for users who prefer to edit and enter the pH values of their buffer solutions, and an “automatic” calibration that provides a buffer-recognition mechanism which locks in on the buffer value most closely representing the combination of millivolts and temperature values being reported from the sensor.

User-programmable stability parameters prevent the transmitter from accepting calibration data until both the pH and temperature signals from the sensor have stabilized. Tables of industry standard buffer values are preprogrammed in the transmitter. For flexibility, a custom buffer table may be user-programmed for unusual application requirements.

COMPATIBLE WITH WIDE RANGE OF SENSORS

876PH Transmitter versions are available to support three groups of pH and ORP sensors, categorized by their electronic configuration.

Analog Sensors Without Preamplifiers

The 876PH-T version transmitter contains an integral high impedance preamplifier, thus permitting it to be used with virtually any glass pH, ISE, or noble metal ORP sensor. Foxboro analog sensors are offered without preamplifiers in versions of the PH10, 871A, 871PH and EP460 Series. The Foxboro PH12 and EP462 Series sensors are only available as analog sensors without preamplifiers. When an analog sensor without preamplifier is used, the Foxboro sensor cable length is limited to 15.2 m (50 ft). The Foxboro product line also includes a remote preamplifier in a field mountable junction box. This remote preamplifier is used when the distance between an analog sensor without preamplifier and the transmitter is greater than 15.2 m (50 ft). The transmitter can be programmed to accept any of three common temperature compensator inputs – 100 ohm platinum RTD, 1000 ohm platinum RTD, and Balco 3000 ohm RTD. This facilitates the use of the 876PH-T with many common non-Foxboro sensors.

Analog Sensors With Preamplifiers

Many Foxboro sensors are offered with integral preamplifiers. These include versions of the PH10, 871A, 871PH and EP460 Series. All of these sensors with integral preamplifiers are compatible with the 876PH-T version transmitter. The use of a preamplifier allows the cable distance between the sensor and transmitter to be extended to 152 m (500 ft).

Smart Digital Sensors

The PH10 sensor is available in a Smart, digital version. With this sensor type, an electronics module in the sensor allows the sensor to store its calibration parameters, as well as other sensor specific information. The 876PH version that supports this Smart, digital sensor is the 876PH-S Series. See Figure 1 for Foxboro sensors compatible with the 876PH Intelligent Transmitter.

BENEFITS OF SMART MEASUREMENT TECHNOLOGY

A principle source of measurement error in electrochemical systems comes from an imperfect field system calibration. Field calibrations can be compromised in many ways, such as not allowing the readings to stabilize, performing a single point calibration when a two point is called for, calibrating a sensor whose slope indicates it is approaching end of life, using calibration solutions whose temperatures are changing, etc. Many of these common sources of calibration errors are mitigated by performing a calibration under more controlled conditions, such as those found in an instrument shop or laboratory. However, it is not practical to move the field transmitter to the instrument shop to perform the calibration.

This is where the advantages of Smart sensor technology come into play. A Smart sensor can be calibrated at any time using a transmitter in the instrument shop or by means of a personal computer (PC) using the Foxboro Smart Sensor PC Interface cable and Device Type Manager (DTM) software (see PH10 PSS 6-1C3A or MI 611-205 for details of the PC Interface and DTM).

The Smart sensor then stores its calibration parameters in an on-board memory chip and uploads them along with sensor identification and history log to any connected transmitter. When a Smart sensor in the field requires calibration, it can be simply swapped out with a recently calibrated sensor or brought to the lab or instrument shop for recalibration. By managing the sensor calibrations in the instrument shop environment, the operator is more likely to perform a valid calibration. This process results in an easier, faster and more reliable field calibration. (For users who prefer to calibrate their sensors in the field, the Smart sensor can also be calibrated in the conventional manner with the 876PH-S field-installed transmitter.)

Figure 1. Foxboro pH and ORP Sensors



QUICK AND INFORMATIVE STATUS

Using the status key, the user gains access to all the information necessary to assess the performance of the measurement loop. Among the parameters this “read only” key accesses are:

- ▶ Process Temperature
- ▶ Slope of pH or ISE Sensor
- ▶ Absolute (Uncompensated) Millivolt Value from pH Sensor
- ▶ ORP Millivolt Value
- ▶ Analog Output Milliamp Value
- ▶ Status of Glass pH Electrode
- ▶ Asymmetry Potential
- ▶ Resistance of Reference Electrode
- ▶ Resistance of Temperature Compensator
- ▶ Date of Last Calibration
- ▶ Location and Device Name
- ▶ Sensor Response Time (876PH-S only)

HISTORY LOGS

There is a transmitter history log with four separate selections that may be viewed and cleared by the user. There is an error selection, an operational selection, a calibration selection and an all history selection. The history log includes all faults, power restore, entries and exits from configuration, calibration and Hold, and faults temporarily suspended.

In addition to the transmitter history log, the 876PH-S Smart transmitter is capable of displaying the sensor history log of a connected PH10-*S Smart pH sensor.

LOCAL HUMAN INTERFACE

A local human interface, as shown in Figure 2, provides local display, diagnostics, and setup. The interface consists of a 128 x 64 dot matrix LCD, a 12-key alpha-numeric keypad, 4 directional arrows, and an ENTER key. Note that the user functions available via the local interface are also available through external interfaces.

UP and DOWN arrows are used to scroll through menu selections, which wrap from the last to the first item. HELP messages appear at the bottom of every display screen, except for measurement displays. If there is a fault, the fault symbol on the title bar will flash. And when the transmitter is in HOLD mode, this is indicated in the upper right of the display (see Figure 4 for location of displays). There is also a full help display accessed via the HELP function key. Help prompt displays also appear before each calibration operation. A typical fault display is shown in Figure 3, and a typical dual measurement display is shown in Figure 4.

Figure 2. Local Human Interface

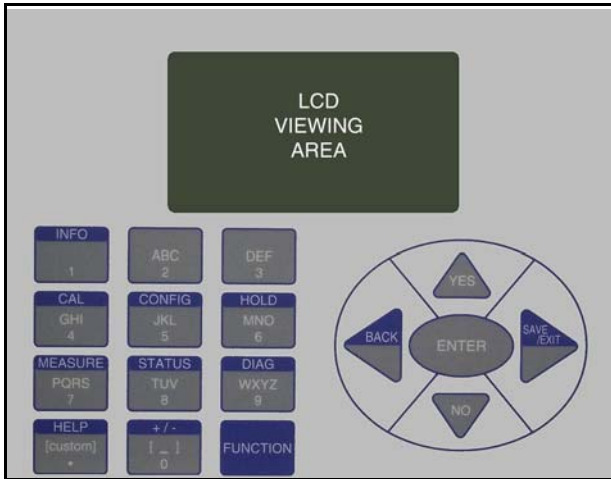

Figure 3. Typical Fault Display

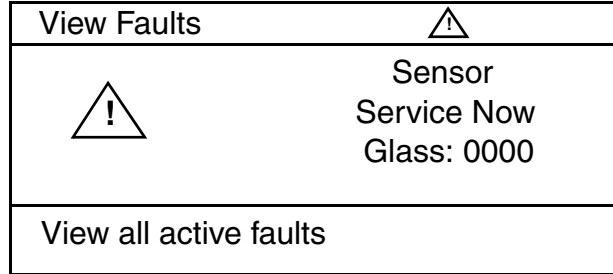
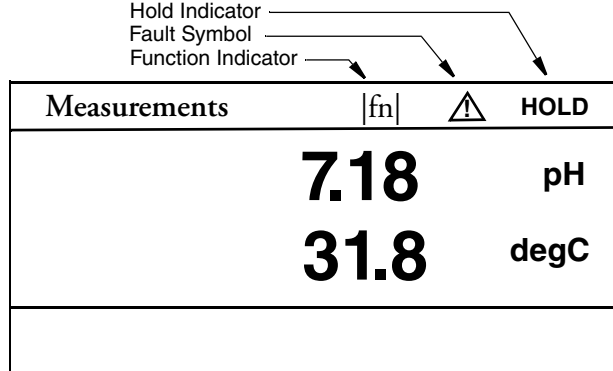

Figure 4. Typical Dual Measurement Display



DISPLAY SIZE AND FORMAT

The LCD viewing area is 71.1 mm wide x 38.9 mm high (2.80 in wide x 1.53 in high), and displays Measurements, Status, Configuration settings, and Calibration settings. The user may configure the interface to display a single measurement, dual, or multiple (3) measurements. Font sizes can be extra large, large, medium, or small, depending on what is being displayed. For example, a single measurement display (pH) would have an extra large font size, while a dual measurement display (pH and temperature) would have a large font size.

SIMULTANEOUS pH AND ORP MEASUREMENT (876PH-T TRANSMITTER)

The 876PH-T transmitter is capable of measuring pH and ORP simultaneously in one of two ways. First, the user may connect separate pH and ORP electrodes to the sensor terminal strip and share the reference electrode from the pH sensor. Alternatively, the user may connect a single combination pH/ORP sensor (such as the Foxboro PH12 version) to the sensor terminal strip. When measuring pH and ORP simultaneously, the transmitter outputs both measurements digitally via the HART protocol. Both measurements may be viewed on the LCD display. For users who need to measure both pH and ORP in the same process solution, this feature greatly reduces cost and space requirements as one transmitter is really doing the job of two.

OPERATING, TRANSPORTATION, AND STORAGE CONDITIONS

Influence	Reference Operating Conditions	Normal Operating Conditions	Transportation and Storage Limits
Ambient Temperature	23 ± 2°C (73 ± 4°F)	-30 to +70°C (a) (-22 to +158°F) (a)	-30 and + 70°C (-22 and +158°F)
LCD Indicator	23 ± 2°C (73 ± 4°F)	-20 to +70°C (a) (b) (-4 to +158°F) (a) (b)	-30 and + 70°C (-22 and +158°F)
Relative Humidity	50 ±10%	5 to 90% (c) Noncondensing	5 and 90% Noncondensing
Supply Voltage Over 4 to 20 mA 2-Wire Line	24 ± 2 V dc	12.8 to 42 V dc See Figure 5	Not Applicable
Output Load	250 Ω	0 to 1300 Ω (Figure 5)	Not Applicable
Isolation	±1 V dc	For Intrinsically Safe Applications: ±24 V dc For General Purpose (Ordinary) Locations: ±42 V dc	Not Applicable
Vibration	Negligible	For Panel Mounting: 2.5 m/s ² (0.25 "g") from 5 to 200 Hz For Pipe or Surface Mounting: 10 m/s ² (1 "g") from 5 to 200 Hz	Protected by Shipping Container

- a. Refer to "Electrical Safety Specifications" on page 18 for a restriction in ambient temperature with certain electrical certifications.
- b. The LCD Indicator may have degraded performance between -20 and -30°C (-4 and -22 °F).
- c. The transmitter will operate at a low limit of 0% RH but with a possible degradation of performance.

PERFORMANCE SPECIFICATIONS

*(Transmitter Specifications under Reference Operating Conditions unless otherwise specified.
Refer to Sensor Literature for Sensor Specifications.)*

Accuracy – Digital Measurement (Includes Linearity, Hysteresis, and Repeatability)

pH Measurement (at 25°C/77°F Reference)

- ±0.009 pH with 3-wire, 1000 ohm RTD
- ±0.011 pH with 3-Wire, 100 Ω RTD
- ±0.011 pH with 2-Wire, 3000 Ω Balco RTD
- ±0.015 pH with 2-Wire, 1000 Ω RTD
- ±0.020 pH with 2-Wire, 100 Ω RTD
- ±0.009 pH with PH10-*S Smart Sensor

ORP Measurement (at 25°C/77°F Reference)

±0.5 mV

ISE Measurement (at 25°C/77°F Reference)

±0.5 mV

Accuracy - Analog Output

Analog output accuracy is equal to the digital measurement accuracy plus an additional 0.04% of full span (4 to 20 mA).

Accuracy – Solution Temperature (at 25°C/77°F Reference)

With 3-Wire 1000 Ω Platinum RTD

±0.03°C (±0.05°F)

With 3-Wire 100 Ω Platinum RTD

±0.1°C (±0.18°F)

With 2-Wire 3000 Ω Balco RTD

±0.1°C (±0.18°F)

With 2-Wire 1000 Ω Platinum RTD

±0.3°C (±0.5°F)

With 2-Wire 100 Ω Platinum RTD

±0.5°C (±0.9°F)

PH10-*S Smart Sensor

± 0.03°C (±0.05°F)

Ambient Temperature Effect on Digital Measurement Accuracy

The effect listed below is for a 28°C (50°F) change in transmitter temperature within Normal Operating Condition limits, unless otherwise noted.

pH Measurement

- ±0.009 pH with 3-wire, 1000 Ω RT
- ±0.009 pH with PH10-*S Smart Sensor

ORP Measurement

±0.5 mV

ISE Measurement

±0.5 mV

Ambient Temperature Effect on Analog Output Accuracy

Digital Measurement effect plus an additional $\pm 0.01\%$ per $^{\circ}\text{C}$.

Ambient Temperature Effect on Solution Temperature Accuracy

The effect below is for a 28°C (50°F) change in transmitter temperature within Normal Operating Condition limits, unless otherwise noted.

With 3-Wire 1000 Ω Platinum RTD

$\pm 0.03^{\circ}\text{C}$ ($\pm 0.05^{\circ}\text{F}$)

With 3-Wire 100 Ω Platinum RTD

$\pm 0.1^{\circ}\text{C}$ ($\pm 0.18^{\circ}\text{F}$)

With 2-Wire 3000 Ω Balco RTD

$\pm 0.1^{\circ}\text{C}$ ($\pm 0.18^{\circ}\text{F}$)

With 2-Wire 1000 Ω Platinum RTD

$\pm 0.3^{\circ}\text{C}$ ($\pm 0.5^{\circ}\text{F}$)

With 2-Wire 100 Ω Platinum RTD

$\pm 0.5^{\circ}\text{C}$ ($\pm 0.9^{\circ}\text{F}$)

PH10-*S Smart Sensor

$\pm 0.03^{\circ}\text{C}$ ($\pm 0.05^{\circ}\text{F}$)

Relative Humidity Effect (5 to 95% RH)

No effect for noncondensing environments.

Supply Voltage and Load Effect**Digital**

Less than 0.005% of full scale/V

Analog

Less than 0.005% of analog scale/V, in addition to digital effect.

Mounting Position Effect

Transmitter meets reference accuracy specifications for all mounting positions.

Output Noise

Included in reference accuracy specifications.

Response Time

Response time is defined as a 90% response to a stepped input change.

pH, ORP, and ISE Measurement (No Temperature Compensation)

Less than 2 seconds with no damping

RTD Measurement

Less than 5 seconds (applies only to 876PH-T)

Measurement Stability

Stability listed is after six months (noncumulative).

pH Measurement

± 0.009 pH at 25°C (77°F) with 3-Wire 1000 Ω RTD or PH10-*S Smart Sensor

ORP Measurement

± 0.5 mV at 25°C (77°F)

ISE Measurement

± 0.5 mV at 25°C (77°F)

Temperature Stability

$\pm 0.05^{\circ}\text{C}$ ($\pm 0.09^{\circ}\text{F}$) after six months (noncumulative)

Common Mode Rejection

120 dB, dc; or 50/60 Hz, ac; between loop and sensor (42 volts peak)

Minimum Output Span**pH Measurement**

0.5 pH

ORP Measurement

32 mV

ISE Measurement

- ▶ Scale - 9999. ppm
Minimum Span = 80 ppm
- ▶ Scale - 999.9 ppm
Minimum Span = 8 ppm
- ▶ Scale - 99.99 ppm
Minimum Span = 0.8 ppm
- ▶ Scale - 9.999 ppm
Minimum Span = 0.08 ppm
- ▶ Scale - 0.9999 ppm
Minimum Span = 0.008 ppm

NAMUR Compliance

The transmitter complies with the following NAMUR Standards:

- ▶ NAMUR NE 43 for analog overrange and underrange annunciations
- ▶ NAMUR NE 21 for interference immunity requirements

Electromagnetic Compatibility (EMC)

The transmitter, when installed in accordance with MI 611-262, complies with the EMC requirements of European EMC Directive 2004/108/EC by conforming to the following EN Standard: EN 61326-1:2006.

FUNCTIONAL SPECIFICATIONS

HART Supply Voltage Requirements and External Loop Load Limitations

See Figure 5.

HART Communications

Configurable for either Analog (4 to 20 mA) or Multidrop Mode. Digital communications is provided in both modes based upon the FSK (Frequency Shift Keying) technique which alternately superimposes one of two different frequencies on the uninterrupted current carried by the two signal/power wires. The digital signal is fully scalable over the operating range of the sensor. Remote configuration is via a HART Communicator, a PC-based configurator (such as the Model PC50 or Model HHT50), or a DCS. Local configuration is via the integral Local Human Interface keypad. The HART communication rate is 1200 baud and measurement updates are 1 time/s.

Direct Connectivity to Foxboro Open Industrial System

The transmitter can be connected directly to a Foxboro System using fieldbus modules (FBMs). A HART FBM applicable to your installation can be provided.

Figure 5. HART 4 to 20 mA Output, Supply Voltage vs. Output Load

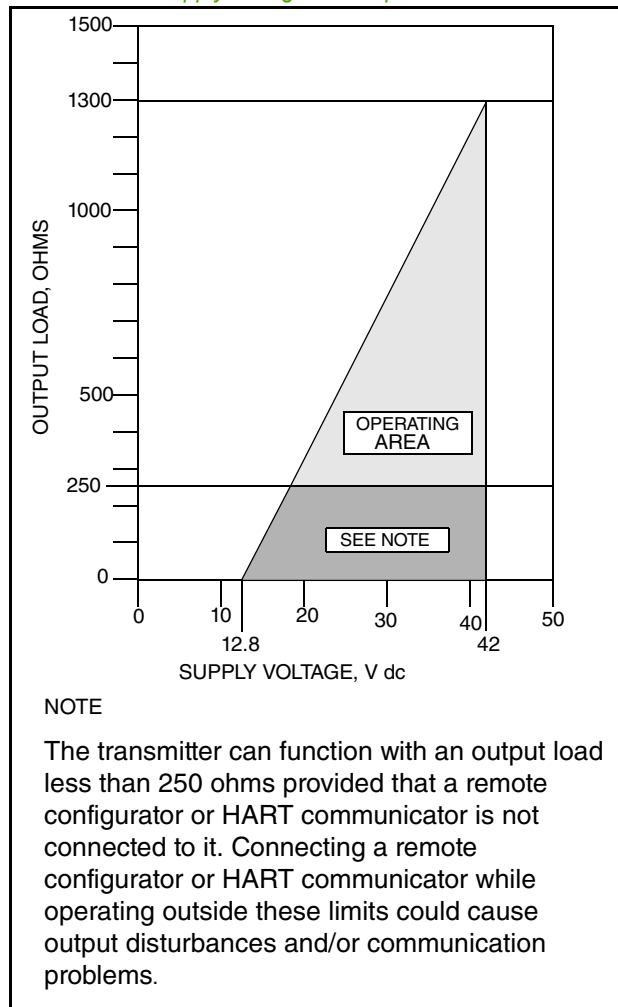

Digital Output

1st Digital Measurement

Independently assignable to pH, ORP, ISE, electrode voltage (absolute), temperature sensor resistance, glass electrode resistance, reference electrode resistance, or solution temperature. Also, the primary measurement (PV) is automatically assigned as the analog output.

2nd, 3rd, and 4th Digital Measurements

Independently assignable to pH, ORP, ISE, electrode voltage (absolute), temperature sensor resistance, glass electrode resistance, reference electrode resistance, or solution temperature.

Factory Default Settings

- PV = pH, ORP, or ISE Measurement
- SV = Solution Temperature
- TV = Electrode Voltage (absolute)
- QV = Temperature Sensor Resistance

Analog Output

- ▶ Configurable to pH, ORP, ISE, or Temperature.
- ▶ Linear output within measurement range.
- ▶ Analog output is configurable for Fail Safe.
- ▶ Analog output hold function.

Output Hold

Output Hold is a feature that allows sensor maintenance such as cleaning or calibration without control system upsets. Both digital and analog outputs can be configured to output hold.

- ▶ OFF: The dynamic output tracks the live sensor readings.
- ▶ PRESENT: The output remains frozen at the last value when output hold was invoked.
- ▶ MANUAL: Output held at a preconfigured value.

Output hold can also be configured for automatic engagement during calibration and configuration sessions.

Fail Safe Output

Fail Safe output is configurable to OFF, FAIL LOW, or FAIL HIGH. The factory default is OFF.

- ▶ OFF: The analog output continues to produce the available measurement without necessarily indicating a failure.
- ▶ FAIL LOW or FAIL HIGH: User-configurable to Fail Low (3.6 mA) or Fail High (22 mA) upon failure, consistent with NAMUR Standard NE 43. The factory default is Fail Low.

Measurement Range – Selectable

pH (Hydrogen Ion Concentration)

-2 to +16 pH

ORP (Oxidation Reduction Potential)

-2000 to +2000 mV

ISE (Ion Selective Electrode Concentration)

0 to 9999 ppmn

Solution Temperature

-30 to +200°C (-22 to +392°F)

Measurement Damping

Measurement damping is continuously adjustable from 0 to 300 seconds.

Temperature Inputs

Factory Precalibrated

- ▶ 100 Ω Platinum RTD, two or three wires
- ▶ 1000 Ω Platinum RTD, two or three wires
- ▶ 3000 Ω Balco RTD, two wire
- ▶ PH10-*S Smart Sensor with 1000 Ohm, Platinum RTD

Input Impedance

10¹² Ω minimum on both pH electrode and reference electrode inputs (with or without external amplifier); screen (shield) drive provided (not applicable to 876PH-S which is digital input only).

Temperature Compensation

pH and ISE Compensation

Adjusts the Nernst slope factor to correct for the variation of the measuring electrode's potential with temperature. Thus, the displayed pH or ISE concentration is the actual measurement of the solution at process temperatures between -30 to +200°C (-22 to +392°F). Optional temperature compensations for 1 ppm ammonia and user-programmed custom curves are available.

ORP Compensation

No temperature compensation is applied to the ORP measurement.

Temperature Compensation Range

- ▶ For pH or ISE –30 to +200°C (-22 to +392°F)
- ▶ For Ammonia: 0 to 100°C (32 to 212°F)

Precalibrated Measurement Range

- ▶ 876PH-T: ±2000 mV
- ▶ 876PH-S: ±1800 mV

Auto Buffer Recognition

Transmitter has six tables of preprogrammed pH buffer values, identified as American, European, National Institute of Standards and Testing (NIST), DIN, JIS, and Merck. Also, seven user programmable tables are available that contain value sets of pH and temperature.

Sensor Compatibility**876PH-T Version**

- ▶ DolpHin PH10 (pH) and ORP10 (ORP)
- ▶ PH12 (pH and ORP)
- ▶ 871PH (pH or ORP)
- ▶ 871A (pH or ORP)
- ▶ EP459A (Fluoride)
- ▶ EP460 (pH)
- ▶ EP462 (pH)
- ▶ EP466 (pH)
- ▶ Non-Foxboro sensors without integral preamplifiers, and with compatible temperature sensors.

876PH-S Version

- ▶ DolpHin PH10 (pH) Smart Version

Continuous Diagnostics

Complete check every eight seconds for diagnostics listed below unless otherwise noted. When diagnostics fail, the most severe failure is displayed. Additional information can then be obtained in the diagnostics menu. All diagnostic failures are reported via the digital protocol. Many will also cause an analog Fail Safe condition as noted below.

Background Sensor Diagnostics

- ▶ Broken Glass Electrode, Fail Safe, 4 seconds
- ▶ Liquid Leakage into Sensor, Fail Safe
- ▶ Measurement Range Checks -outside ±2000 mV (876PH-T) and ±1800 mV (876PH-S), Fail Safe
- ▶ Temperature Sensor Range checks (short, open, off table), Fail Safe
- ▶ Failed Preamplifier, Fail Safe
- ▶ Fouled or Dry Reference Junction
- ▶ Sensor Disconnected (876PH-S only)

NOTE

Fail Safe = This diagnostic will cause the output to go to Fail Safe if Fail Safe is configured High or Low.

Background Electronics Self-Diagnostics (All Fail Safe)

- ▶ Checksum, EEPROM, EPROM, and RAM Image of Database
- ▶ Code Space Checksum
- ▶ Stack Checking
- ▶ Watch-Dog Timer
- ▶ Verify Readable Processor Registers
- ▶ Analog to Digital Converter

Application Diagnostics

- ▶ Compensation Range Checks (outside selected range for temperature compensation or concentration). Causes Fail Safe, if enabled.
- ▶ Analog Output Overage and Underrange. Causes Fail Safe, if enabled.

Calibration Diagnostics

- ▶ Measurement Slope (pH and ISE only)
- ▶ Aging Glass Electrode
- ▶ Response Time (876PH-S only)

Diagnostics Status

Indicators available to the user in status mode by pressing the DOWN ARROW key.

- ▶ Solution Temperature Display
- ▶ Absolute Input (mV) Display
- ▶ Status Measurement Slope % Display (pH and ISE only)
- ▶ Status Time of Last Calibration Display
- ▶ Other Device Status Displays
- ▶ Sensor identification (876PH-S only)

Valid Configuration Check

Once a user configuration session is complete, the configuration is validated as a whole. If valid, the user is given the choice to accept the configuration or abort and return to the previous configuration.

If any part of the configuration is invalid, the problem is indicated to the user and the user can choose to fix the problem or abort.

Calibration

For each user calibration type, the user is provided with detailed, step-by-step instructions on screen.

History Log

A history log of the most recent events is stored in nonvolatile memory. Events include power up, diagnostic detection, pass code entry, configuration, calibration, and output hold entry and exit.

Sensor history for 876PH-S only

The 876PH-S transmitter is used for calibration of the PH10-*S sensor, the history of which is appended to existing history within the sensor. All sensor-independent parameters in the 876PH-S transmitter can be configured without an attached sensor. When the transmitter detects that a sensor has been connected, it automatically uploads the most recent set of calibration and configuration data from the sensor. When a power cycle occurs, the 876PH-S transmitter uploads the most recent complete set of calibration and configuration data from a connected sensor.

The PH10-*S sensor stores data such as date of manufacture, serial number, sales order number, model code, slope, asymmetry potential, aging, and response time. The data on slope, asymmetry potential, aging, and response time are included in the status menu of 876PH-S transmitter. The last four parameters are stored in a sensor history log, along with Glass and Reference Resistance. Resistance measured at last calibration and sensor and transmitter history data are stamped with real dates and times.

Passcode

Two configurable user passcode levels are supported.

Write Protect Jumper

A write protect jumper provides additional security by allowing the user to prevent the local indicator (configurator) and remote configurator from writing to the electronics. This write protection capability meets the security requirements of ISA-584.01-1986.

Functional Block Diagrams

Refer to Figures 6 and 7.

Figure 6. HART 4 to 20 mA Topology

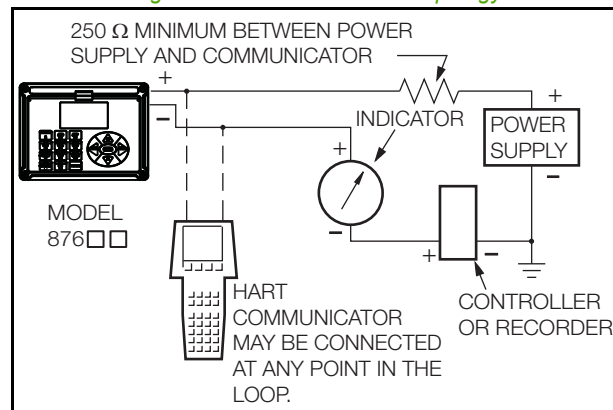
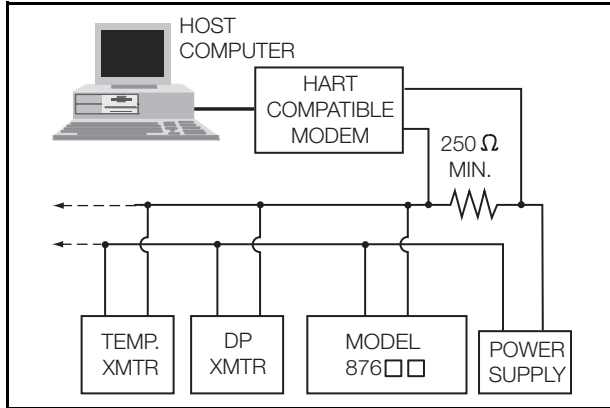

Figure 7. HART Multidrop Topology



PHYSICAL SPECIFICATIONS

Transmitter Enclosure

The transmitter enclosure comprises a housing and hinged bezel assembly. The bezel assembly attaches to the housing with captive screws, with a gasket seal between them.

Housing and Bezel Material

- ▶ Aluminum alloy (with a maximum copper content of 1%).
- ▶ Clear lexan window on bezel assembly.

Gasket Material

Silicone Rubber

Environmental and Corrosion Resistant Protection

The enclosure has the dust tight and weatherproof rating of IP66 as defined by IEC 60529 and provides the environmental and corrosion resistant protection rating of NEMA 4X.

Storm Door (Optional)

Made from a 0.90 inch thick, clear plastic with a polished finish.

Keypad

Durable, clear thermoplastic

Display

Liquid Crystal Display (LCD)

Transmitter Mounting

Transmitter can be panel or surface-mounted, or mounted to a DN 50 or 2-in pipe. A bracket is provided for surface or pipe mounting. See “Dimensions–Nominal” on page 20 for details.

Sensor Cable Length

Analog Sensor with Preamplifier

152 m (500 ft) maximum. Note that preamplifier may also be in a remote junction box.

Analog Sensor without Preamplifier

15.2 m (50 ft) maximum

Smart Sensor

100 m (328 ft) maximum

Approximate Weight

Panel Mounted Transmitter

3.1 kg (6.8 lb)

Surface/Pipe Mounted Transmitter

3.7 kg (8.1 lb); includes mounting bracket

Electrical Connections

876PH-T and 876PH-S Transmitter

Field wires enter through three cable entry holes at the bottom surface of the housing. Two disposable polyethylene plugs are fitted into two holes, and the third hole is fitted with a NEMA plug (for use if additional wiring is necessary). The field wires terminate at screw terminals

located on a PWA (see Figure 8 for 876PH-T and Figure 9 for 876PH-S) located within the enclosure. These terminals are accessible by swinging down the hinged front cover. The cable entry holes are sized to accommodate standard wiring conduit or cable glands. For 876PH-S, a cord grip is supplied and should be used to seal the sensor cable.

Figure 8. Electrical Connections for 876PH-T Transmitter

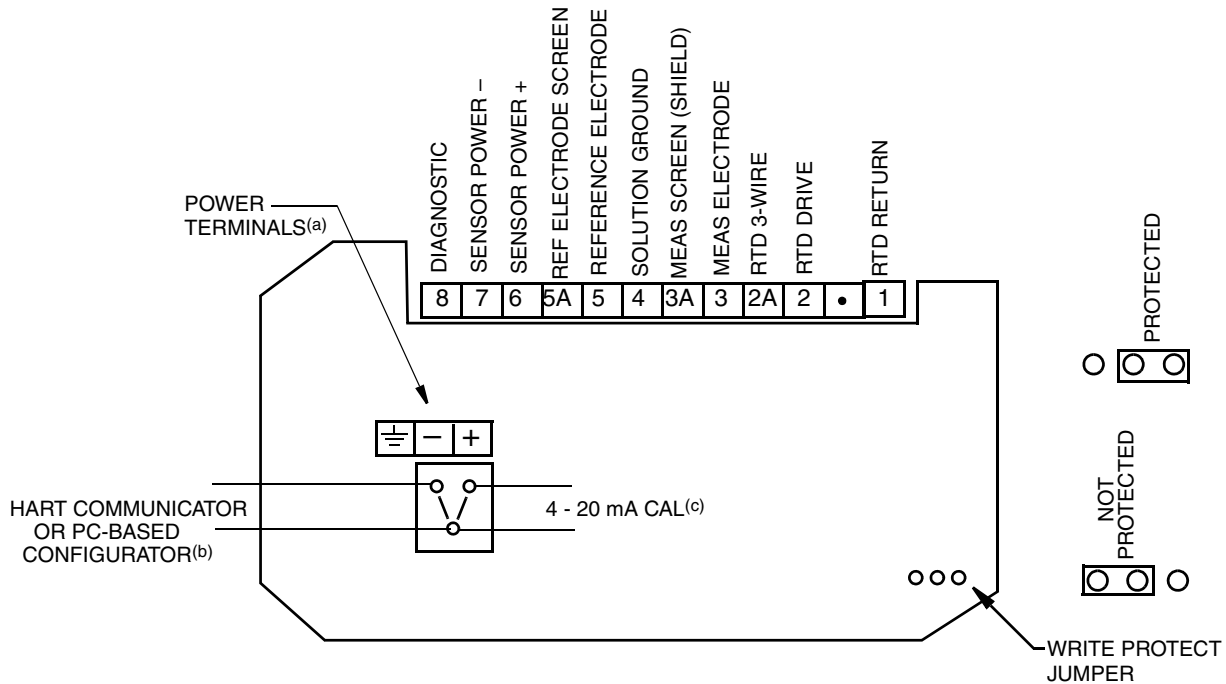

NOTE

When using non-Foxboro sensors for simultaneous pH and ORP measurement, connect pH electrode to 3, reference electrode to 5, and ORP electrode to 4.

Figure 9. Electrical Connections for 876PH-S Transmitter

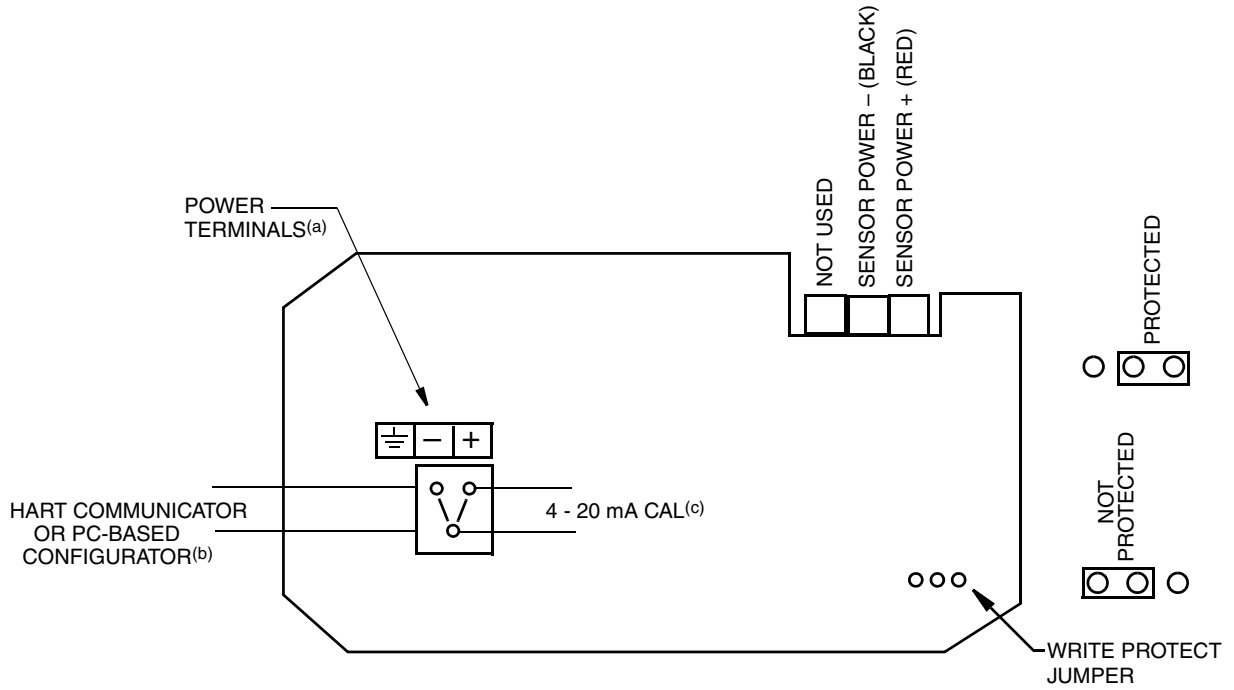

ELECTRICAL SAFETY SPECIFICATIONS

Testing Laboratory, Types of Protection and Area Classification	Application Conditions	Electrical Safety Design Code
ATEX II 1 G, Ex ia IIC, intrinsically safe for Zone 0.	Temperature Class T4. Ta = -20 to +60°C.	AA
ATEX II 3 G, Ex ic IIC, intrinsically safe for Zone 2.	Temperature Class T4. Ta = -20 to +60°C.	AN
CSA Ex ia IIC; intrinsically safe for Zone 0; and CSA intrinsically safe, Class I, II, III, Division 1, Gas Groups A, B, C, D, E, F, G.	Temperature Class T4. Ta = -20 to +60°C.	CA
CSA Ex nL IIC; energy limited for Zone 2; and CSA for Class I, II, III, Division 2, Gas Groups A, B, C, D, E, F, G.	Temperature Class T4. Ta = -20 to +60°C.	CN
FM AEx ia IIC; intrinsically safe for Zone 0; and FM intrinsically safe, Class I, II, III, Division 1, Gas Groups A, B, C, D, E, F, G.	Temperature Class T4. Ta = -20 to +60°C.	FA
FM AEx nC IIC; energy limited for Zone 2; and FM nonincendive, Class I, II, III, Division 2, Gas Groups A, B, C, D, E, F, G.	Temperature Class T4. Ta = -20 to +60°C.	FN
IECEx II 1 G, Ex ia IIC; intrinsically safe for Zone 0.	Temperature Class T4. Ta = -20 to +60°C.	DA
IECEx II 3 G, Ex ic IIC; intrinsically safe for Zone 2.	Temperature Class T4. Ta = -20 to +60°C.	DN
NEPSI Ex ia IIC Ga; intrinsically safe for Zone 0. (a)	Temperature Class T4. Ta = -20 to +60°C.	NA
NEPSI, Ex ic IIC Gc; intrinsically safe for Zone 2.	Temperature Class T4. Ta = -20 to +60°C.	NN
No Certifications	N/A	ZZ

a. NEPSI options only available with 876PH-T.

NOTE

1. Entity Parameters are as listed below:

- Intrinsically Safe Entity Parameters: $V_{max} = 30$ V, $I_{max} = 110$ mA, $P_{max} = 0.8$ W
- Nonincendive (Energy Limited) Entity Parameters: $V_{max} = 42$ V, $I_{max} = 22$ mA
- Sensor Output Entity Parameters: $V_o = 8.6$ V, $I_o = 40$ mA, $P_o = 35$ mW

2. These transmitters have been designed to meet the Electrical Safety Specifications listed in the table above. Contact Global Customer Support (see back page) for the status of Agency approvals or certifications.

MODEL CODE

<u>Description</u>	<u>Model</u>
Intelligent Transmitter for pH, ORP, and ISE Measurement	876PH
Input and Output Communications	
Analog Sensor Input with Digital HART and 4 to 20 mA Output	-T
Smart pH Sensor Input with Digital HART and 4 to 20 mA Output (a)	-S
Enclosure Mounting	
Panel Mounting	W
Surface Mounting	X
Pipe Mounting (Horizontal or Vertical Pipe)	Y
Electrical Safety (Also see “Electrical Safety Specifications” on page 18)	
ATEX intrinsically safe; II 1 G, Ex ia IIC, Zone 0.	AA
ATEX intrinsically safe for II 3 G, Ex ic IIC, Zone 2.	AN
CSA intrinsically safe; Class I, II, III, Division 1; and Ex ia IIC, Zone 0.	CA
CSA for Class I, II, III, Division 2; and energy limited for Ex nL IIC, Zone 2.	CN
FM intrinsically safe; Class I, II, III, Division 1; and AEx ia IIC, Zone 0.	FA
FM nonincendive for Class I, II, III, Division 2; and energy limited for AEx nC IIC, Zone 2.	FN
IECEX intrinsically safe; II 1 G, Ex ia IIC, Zone 0.	DA
IECEX intrinsically safe II 3 G, Ex ic IIC, Zone 2.	DN
NEPSI, Ex ia IIC Ga; intrinsically safe for Zone 0	NA
NEPSI, Ex ic IIC Gc; intrinsically safe for Zone 2	NN
No Certification	ZZ
Optional Selections	
Special per Engineering Order (b)	-1
Storm Door (c)	-7
Detailed Instruction Manual (d)	-M
Example: 876PH-TXFA-7	

- a. ORP and ISE not supported in the -S option.
- b. Provides ability to preconfigure the instrument with custom temperature compensation.
- c. Used to protect front panel controls, particularly in field mounting applications.
- d. A CD-ROM is shipped as standard with each transmitter.

DIMENSIONS-NOMINAL

$\frac{\text{mm}}{\text{in}}$

TRANSMITTER ASSEMBLY

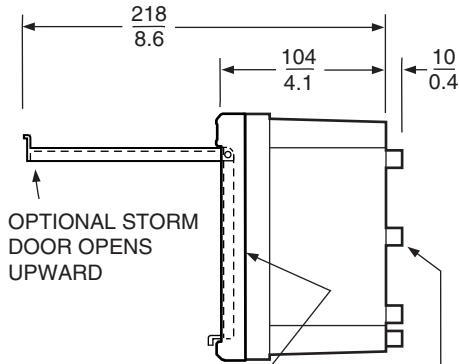
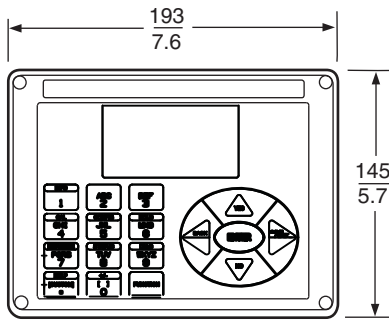

GASKET BETWEEN
CASE AND HINGED
FRONT COVER.

FOUR BOSSES ON REAR SURFACE
TAPPED 0.250-20, 6.4 mm (0.25 in)
DEEP ARE USED FOR SURFACE OR
PIPE MOUNTING OF TRANSMITTER.
CENTERS OF BOSSES ARE ON A
89 mm (3.5 in) BOLT CIRCLE.

FRONT COVER
HINGES DOWNWARD.

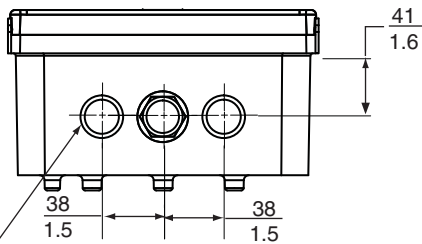

TWO 22 mm (0.87 in) DIAMETER
HOLES FOR FIELD WIRING ENTRY.
NEMA PLUG IN CENTER HOLE CAN
BE REMOVED FOR ADDITIONAL WIRING.
FOR 876PH-S, A CORD GRIP IS SUPPLIED
SEPARATELY AND SHOULD BE USED TO
SEAL THE SENSOR CABLE.

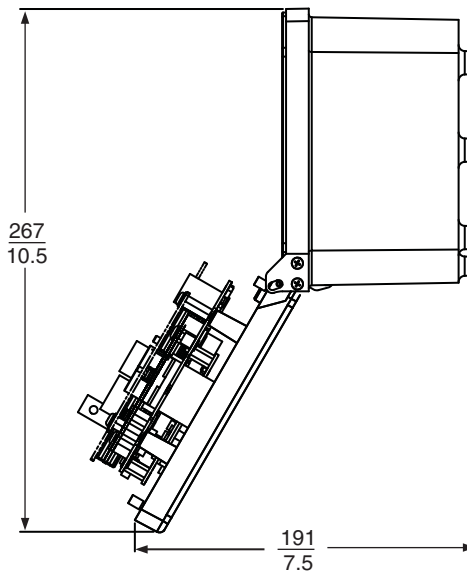

$\frac{\text{mm}}{\text{in}}$

TRANSMITTER MOUNTING

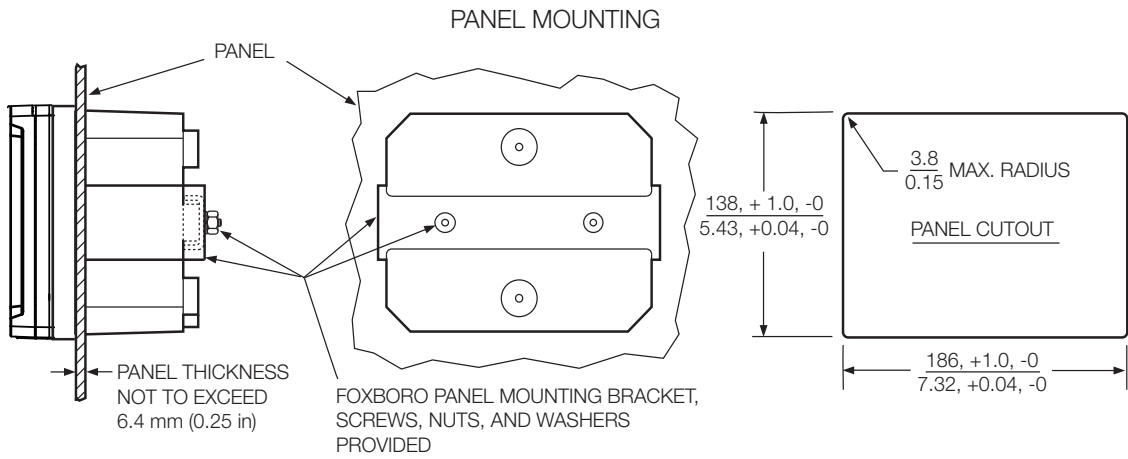

SURFACE MOUNTING

FOXBORO SURFACE MOUNTING BRACKET, SCREWS, AND WASHERS PROVIDED

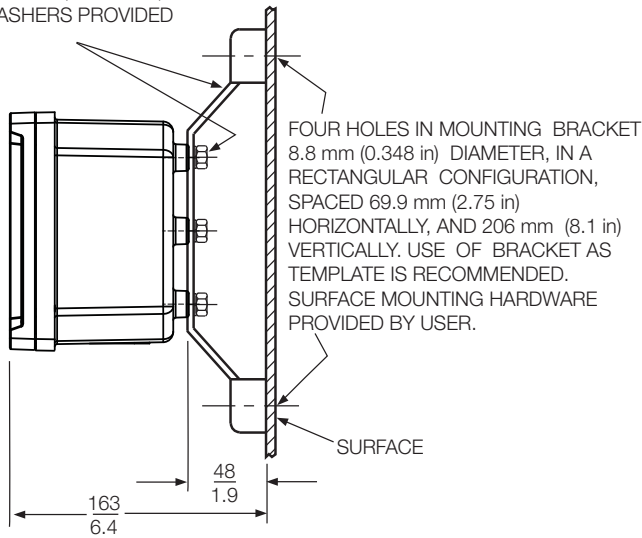

PIPE MOUNTING

FOXBORO PIPE MOUNTING BRACKET, SCREWS, AND WASHERS PROVIDED

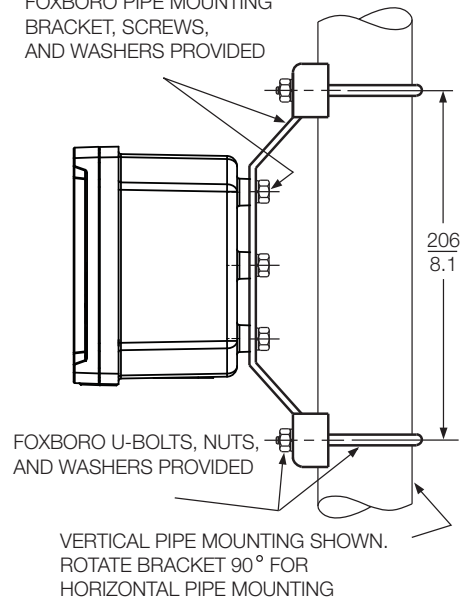

REFERENCE DOCUMENTS

Document Number	Document Description
PSS 2A-1Z3 G	Model PC50 Field Device Tool (FDT) for Use with Intelligent Field Devices
PSS 2A-1Z3 L	Model HHT Configurator for Use with Intelligent Field Devices
PSS 6-1C2 A	871PH Series pH and ORP Sensors and Accessories
PSS 6-1C2 B	871A Series pH and ORP Sensors and Accessories
PSS 6-1C3 A	DolpHin Series pH and ORP Sensors and Accessories
PSS 6-1C5 A	PH12 Series 12 mm, pH and ORP Sensors and Accessories
PSS 6-1C6 A	EP462 Series pH Sensors -Twist-Lock Mount
MI 611-205	PH10 DolpHin™ Series pH Sensors and ORP10 DolpHin Series ORP Sensors Installation, Troubleshooting, Maintenance, and Parts List
MI 611-206	Intrinsic Safety Connector Diagrams - FM, CSA, and IECEx
MI 611-208	Electrochemical Products Product Safety Information - ATEX
MI 611-262	876PH Intelligent Transmitter for pH, ORP, and ISE Measurements
Bulletin K99-1	EP459A Fluoride Sensor Assembly
Bulletin K99-2	EP460 Series, pH Sensors, Universal Mount
Bulletin K99-3	EP462 Series, pH Sensors, Twist-Lock Mount
Bulletin K99-4	EP466 Series, pH Sensors, Insertion/Retractable Mount

NOTES

ORDERING INSTRUCTIONS

1. Model Number.
2. Measurement Range.
3. Measurement Electrode Type; Specify Glass pH, Antimony pH, ORP, or ISE.
4. Temperature Compensation Input; Platinum or Balco RTD Type, Resistance, and 2- or 3-wires.
5. User Tag and Application.

OTHER FOXBORO PRODUCTS

The Foxboro product lines offer a broad range of measurement and instrument products, including solutions for pressure, flow, analytical, temperature, positioning, controlling, and recording. For a list of these offerings, visit our web site at:

www.fielddevices.foxboro.com